

Shell Refining Company (FOM) Berhad
Quarter 1 2006
Investor Briefing

29th May 2006



Background Information



SRC's Refinery in Port Dickson

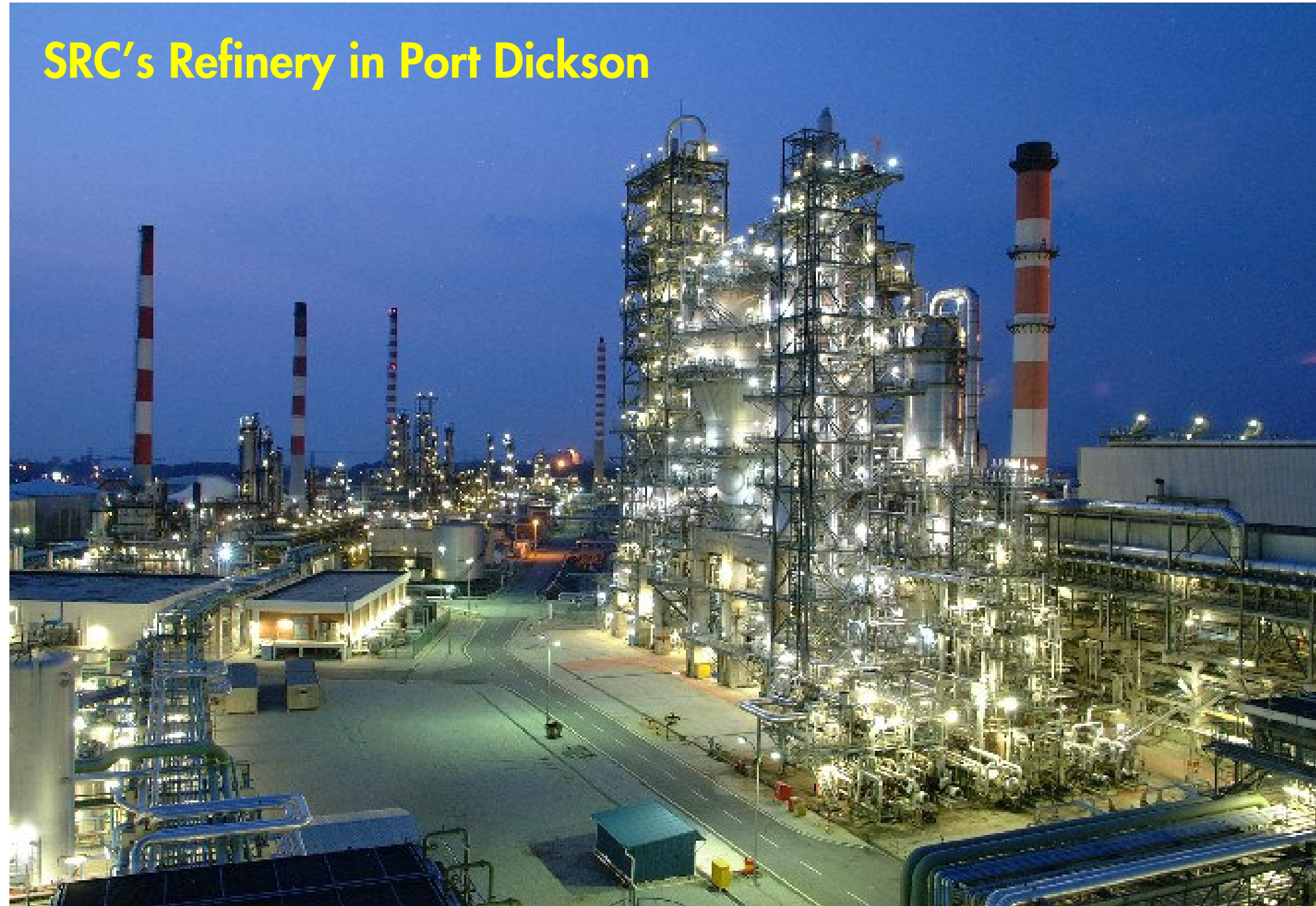

Pre LRCC

105,000 barrels per day

Crude Oil

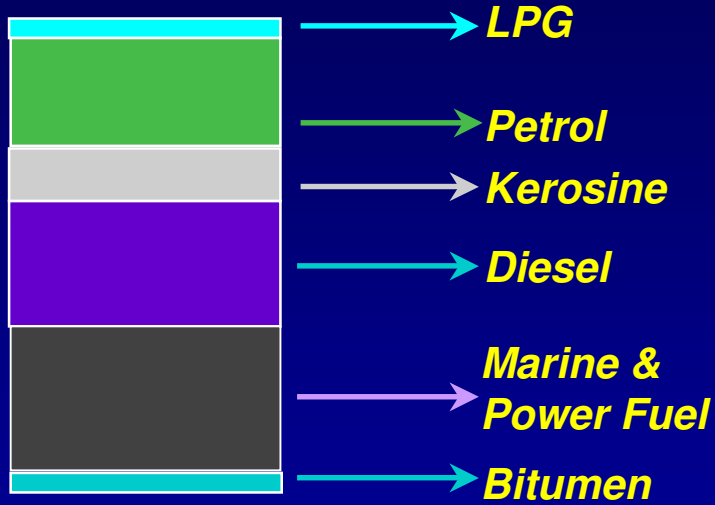

Post LRCC

125,000 barrels per day

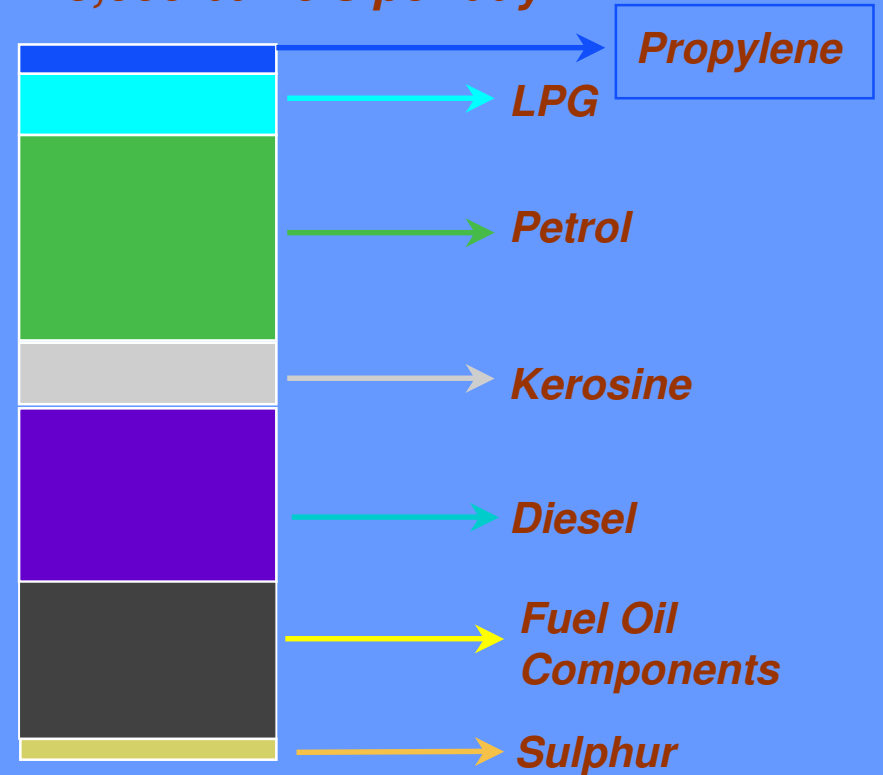

The LRCC:

- Enabled premium products to be produced – V-Power, Propylene
- Quadrupled LPG production
- Doubled motor gasoline output



SRC Product flow to customers

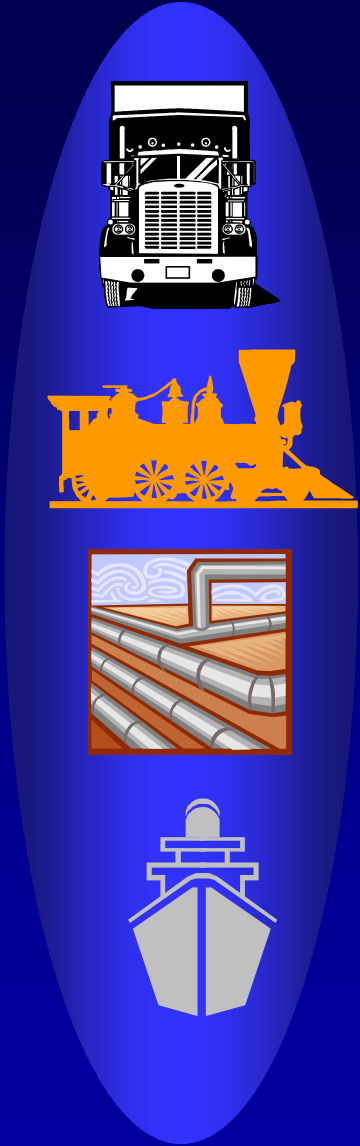
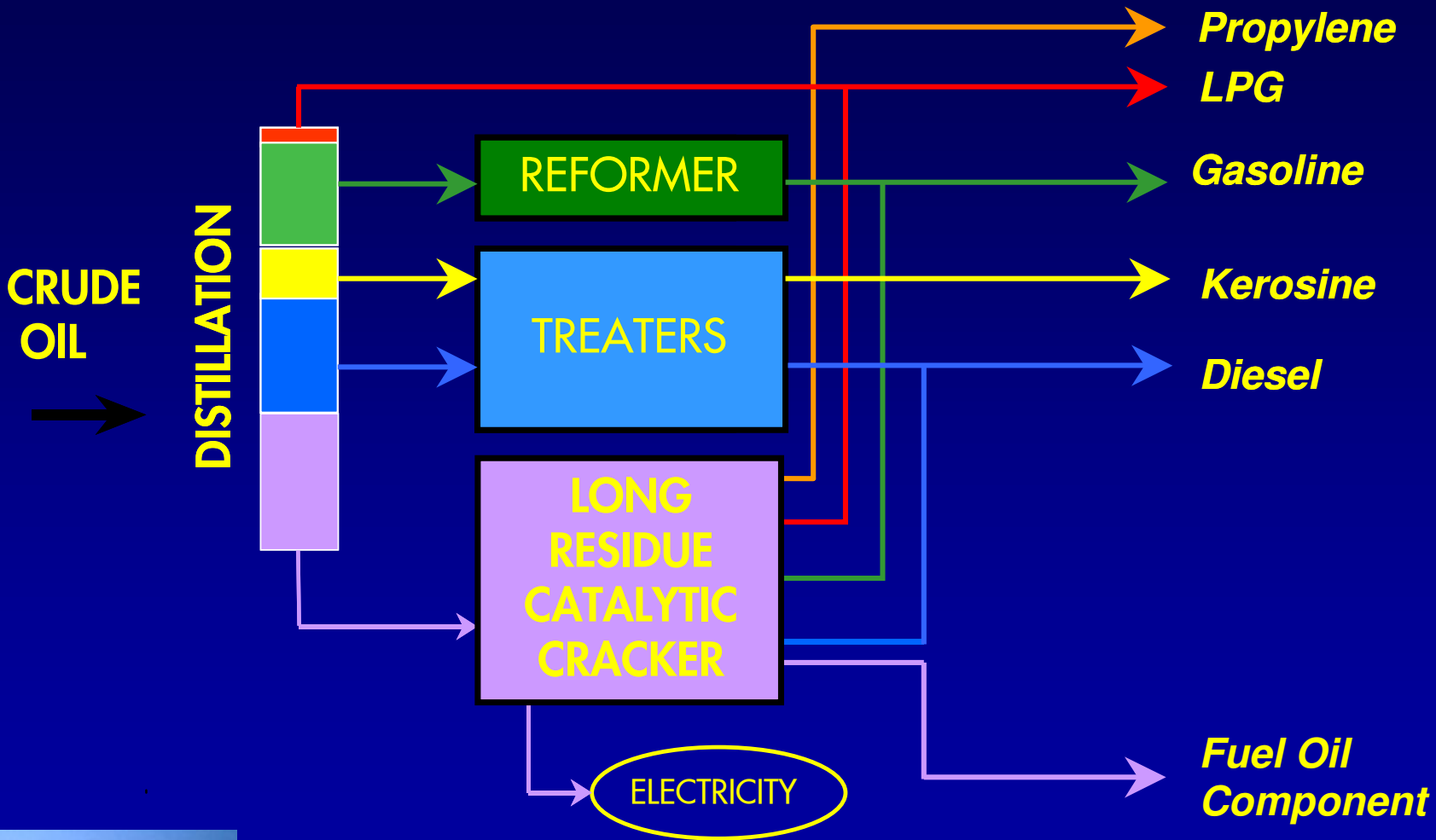

Crude Price Trend

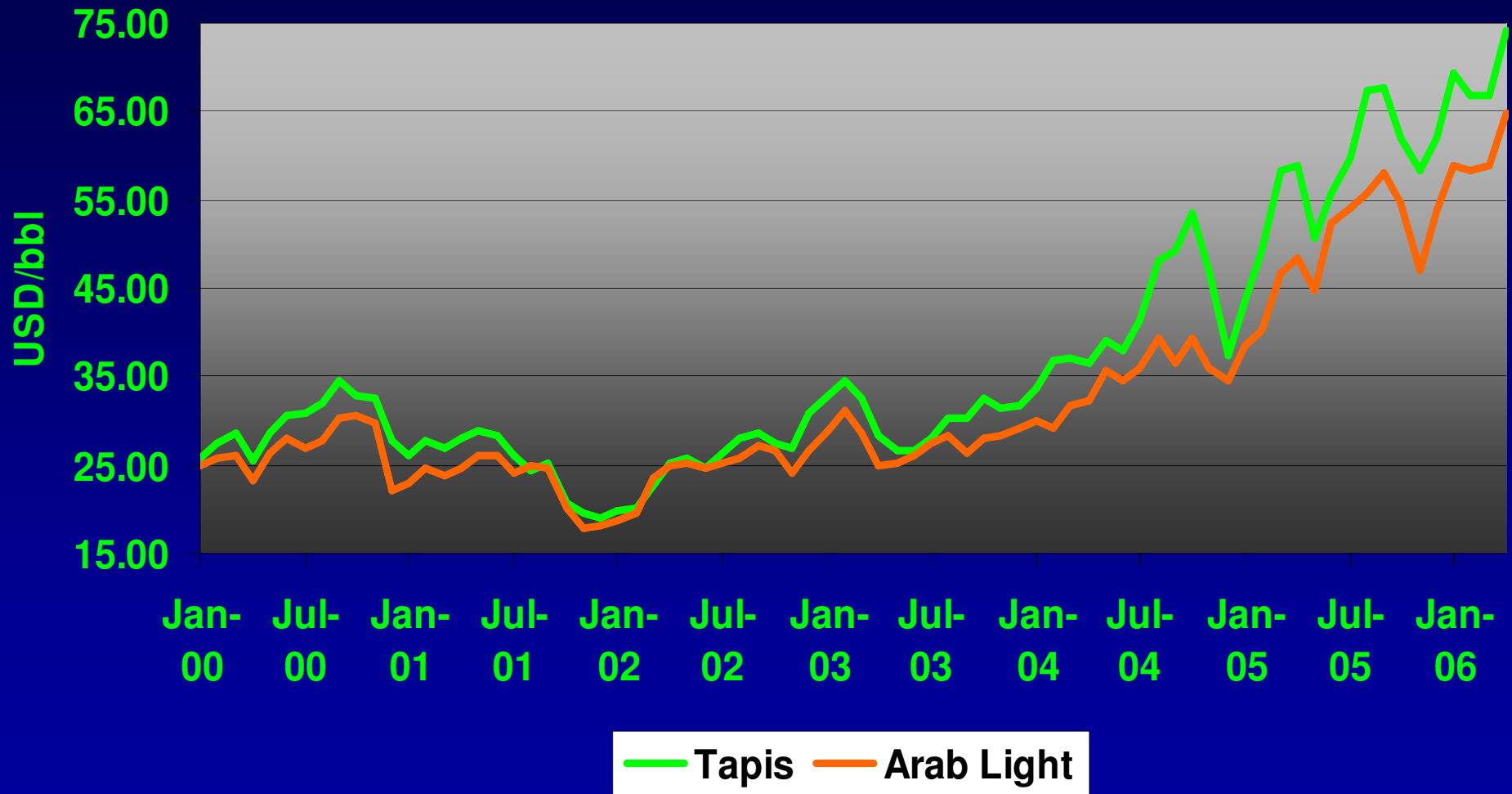

— Tapis — Arab Light



Tapis - Oil Products Spread

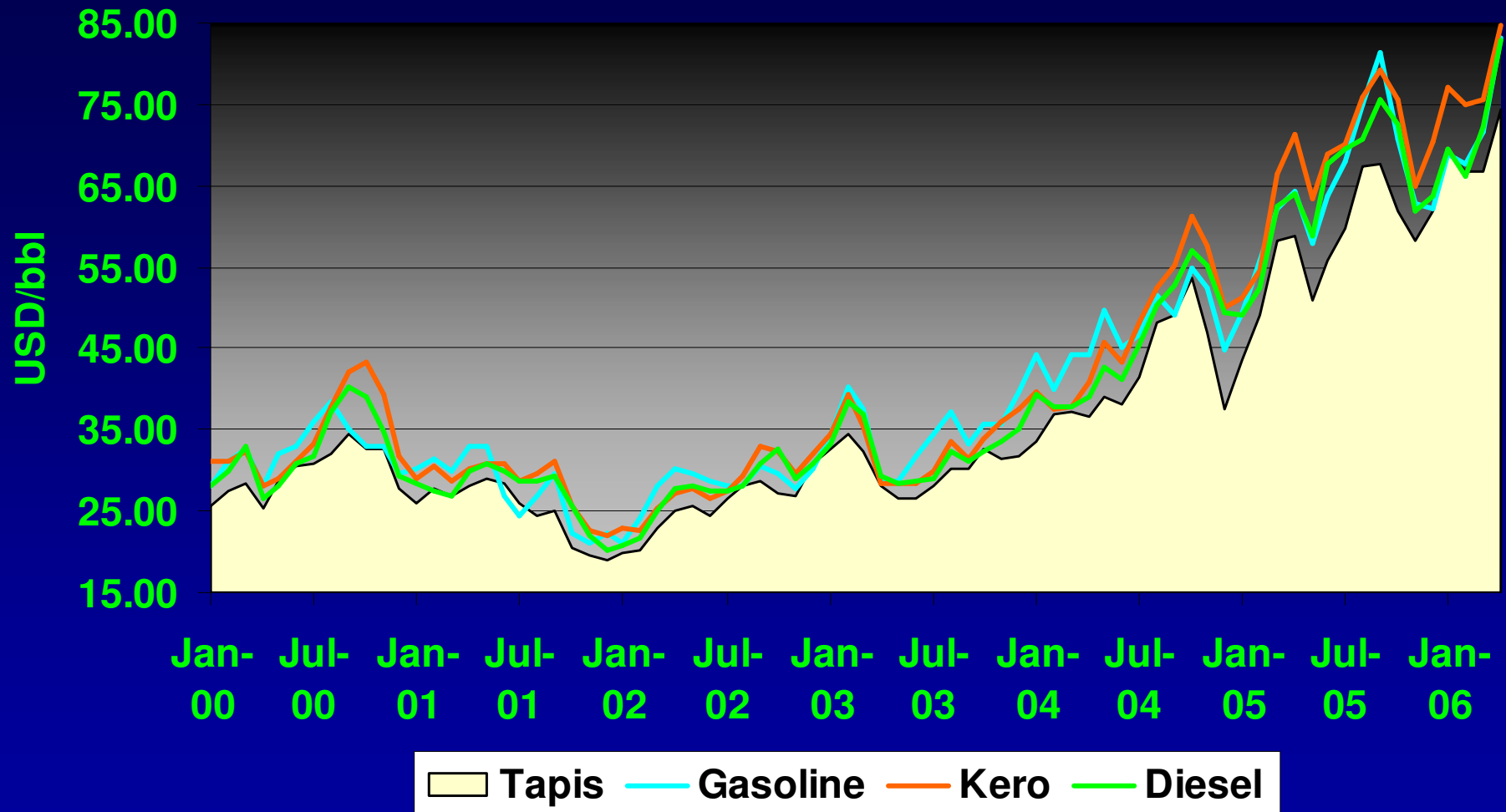

Refining Margin Composition

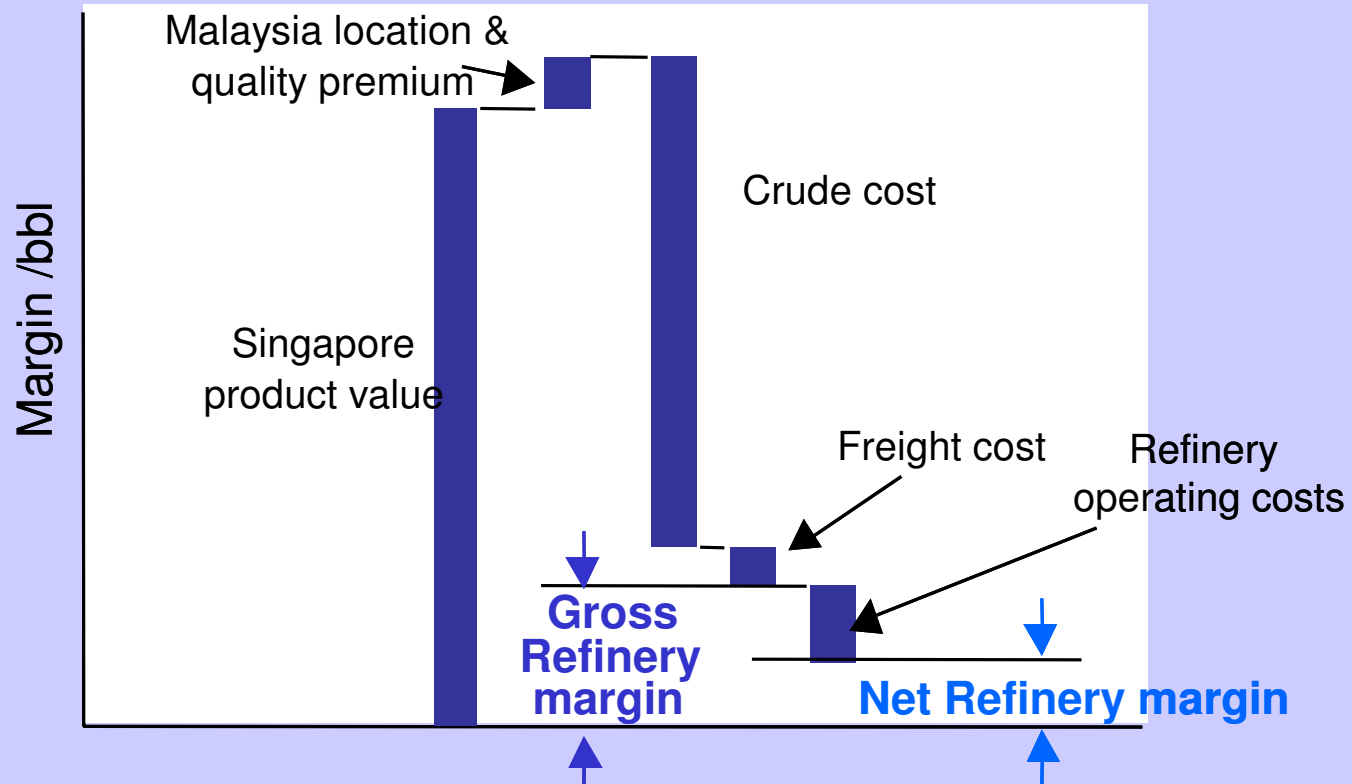

Singapore Refinery Margins⁺ – Complex Vs. Simple*

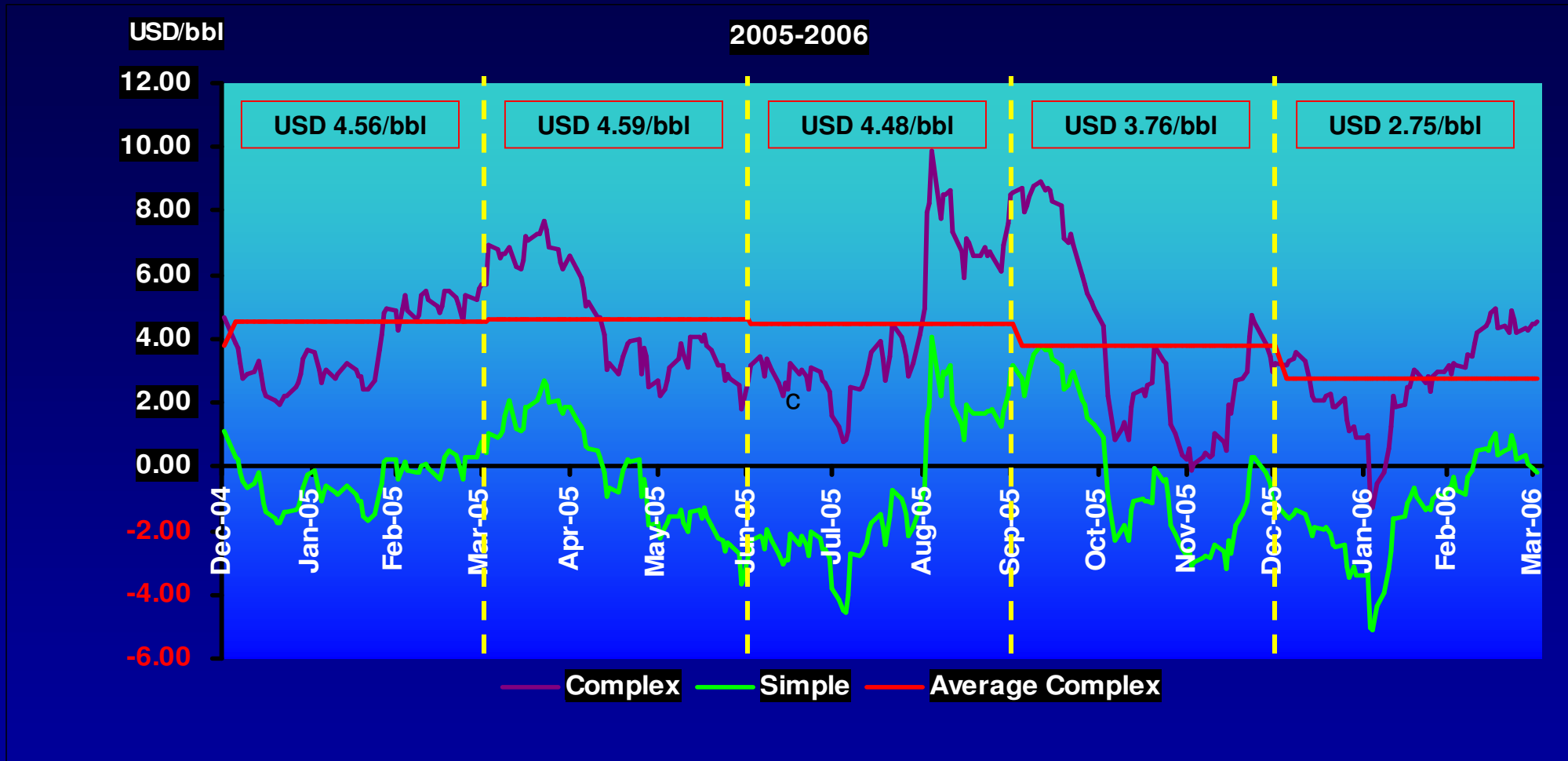

Average Simple Margins:
 2005: - USD 0.43/bbl
 2006: - USD 0.61/bbl

+ Gross Refining Margin basis
 * Daily data



SRC Refinery Margins+ – Complex Vs. Simple*

USD/bbl

2005- 2006

SRC margin have locational and quality Advantage over Singapore margins

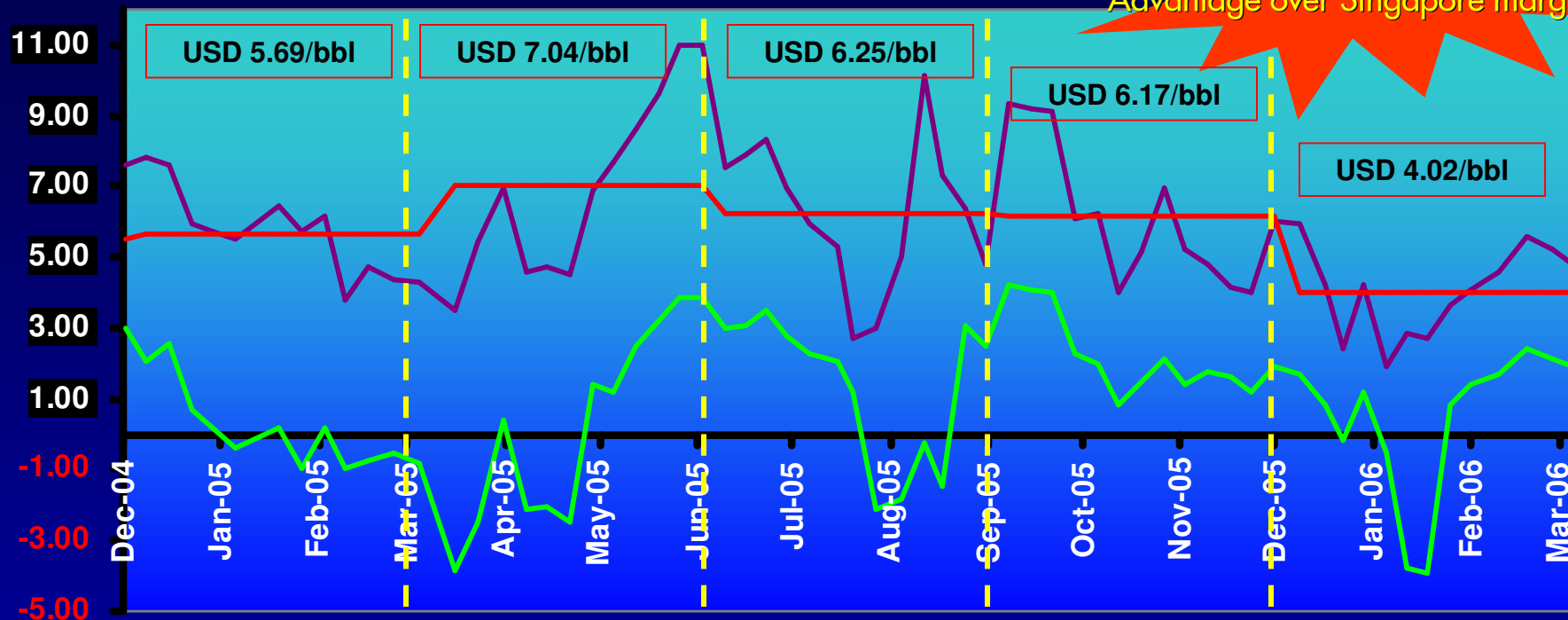

— Complex — Simple — Average Complex

Average Simple Margins:
 2005: + USD 1.03/bbl
 2006: + USD 0.92/bbl

+ Gross Refining Margin basis
 * Weekly data



SRC Performance



SRC – Crude Type

FE-Light or Equity	FE-Heavy	ME
Tapis Labuan Bintulu Bintulu Condensate	Bach Ho Minas Ruby Kekwa XiJiang Widuri Cinta	Oman Murban



SRC Refinery Intake – Sources of Supply

2005

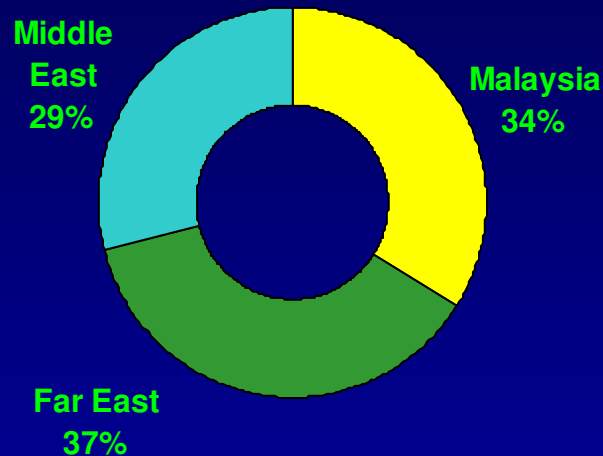

Quarter 1 2006

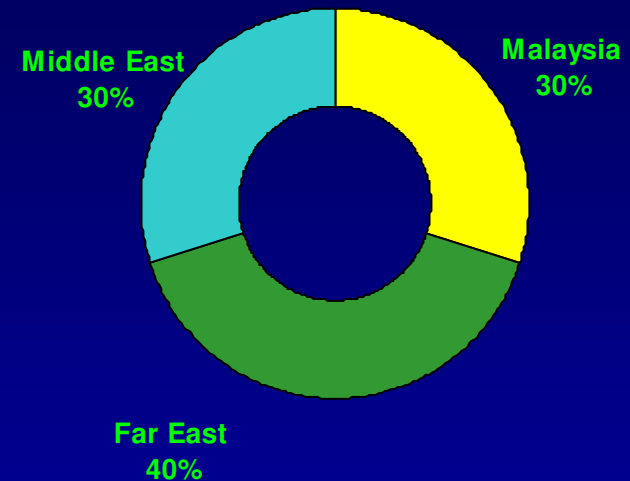

- SRC typically processes between 29-30% Middle East heavy crudes and between 37-40% Far East heavy crudes, and only around 30-34% Malaysian light crudes.
- The decision on which crude we procure depends on the relative economic attractiveness; the flexibility to vary the crude feedstock and product output is important for the Company.



Malaysian Oil Products Demand Quarter 1 2006 by product category

Malaysian Demand Mix 2005

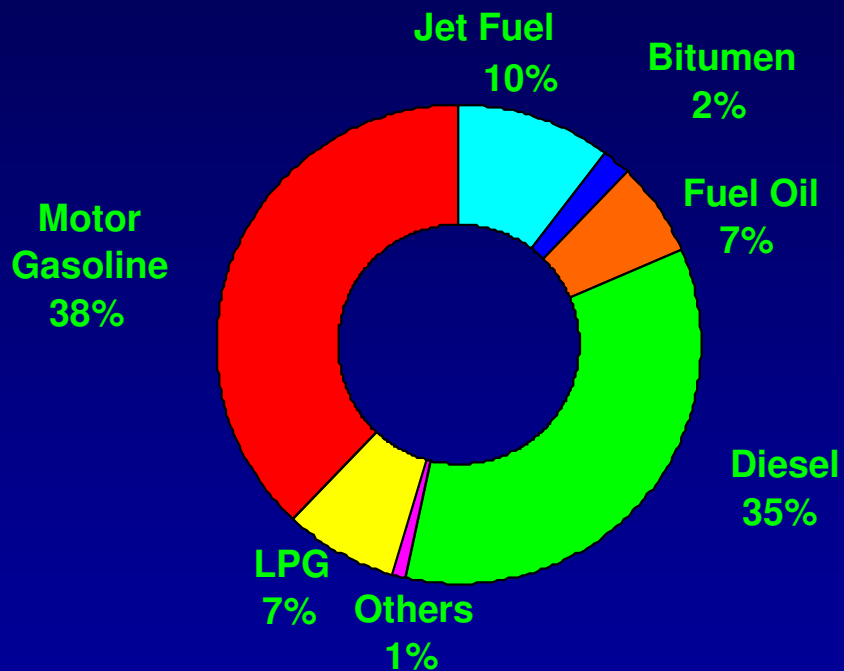

SRC Sales Mix Q1 2006

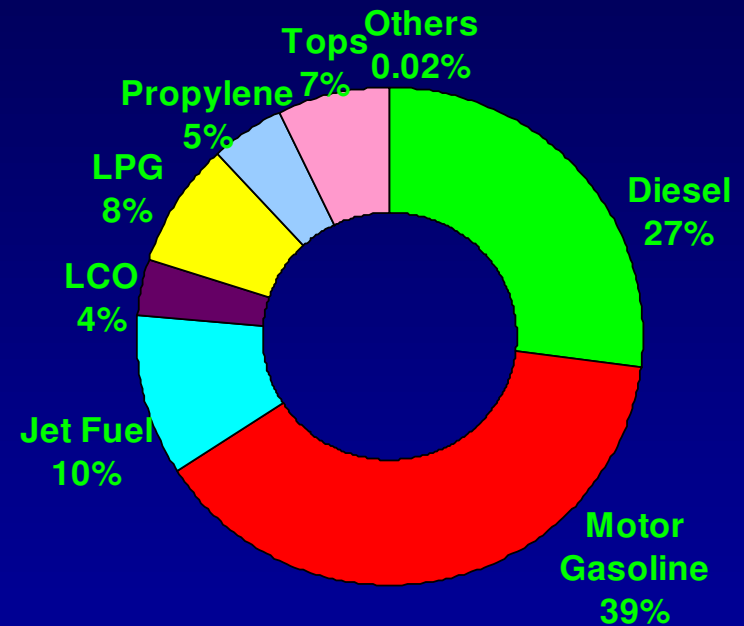

Total Malaysian Demand 2005 = 462 kbbl/day



SRC Average Production Volume Per Day 2001-2006

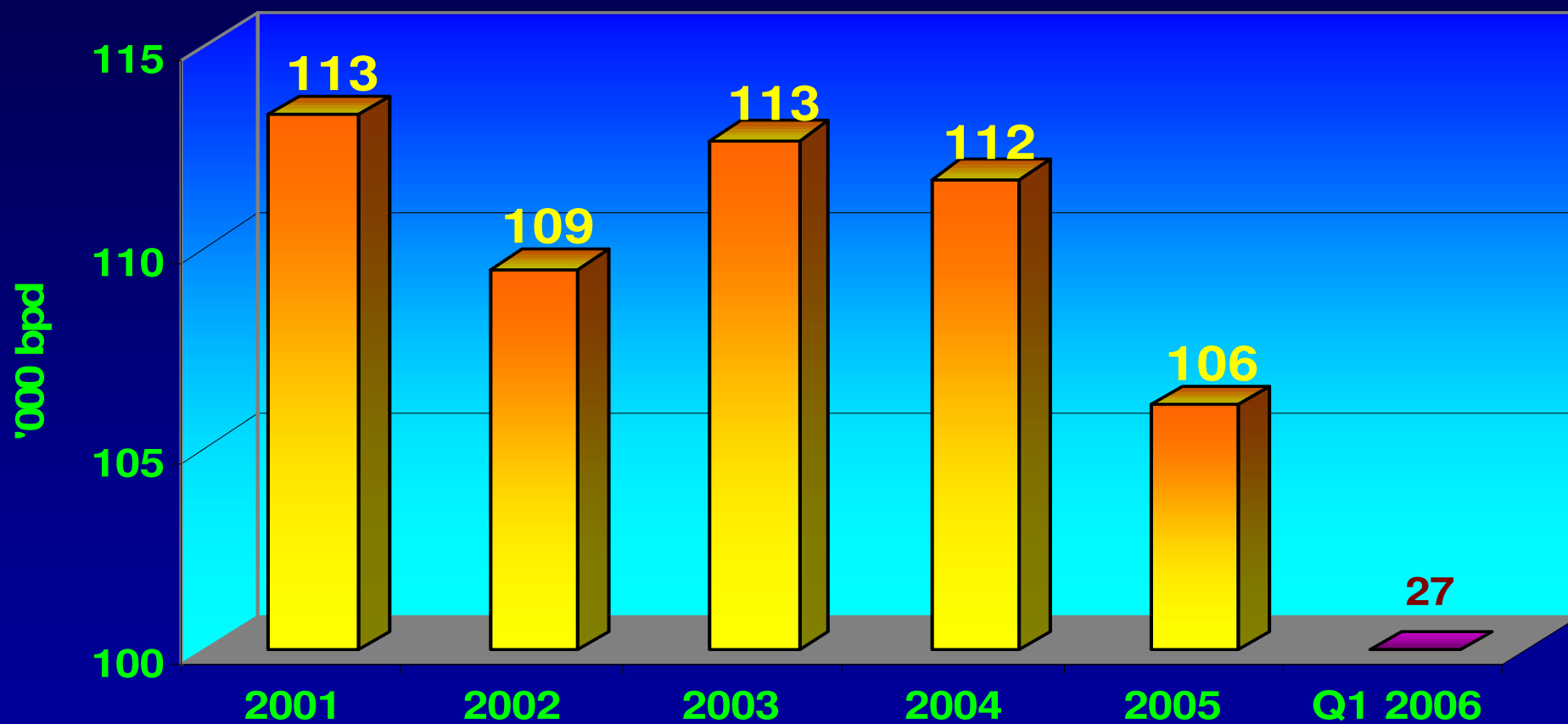

SRC Average Production Volume Per Day 2006 by Quarter

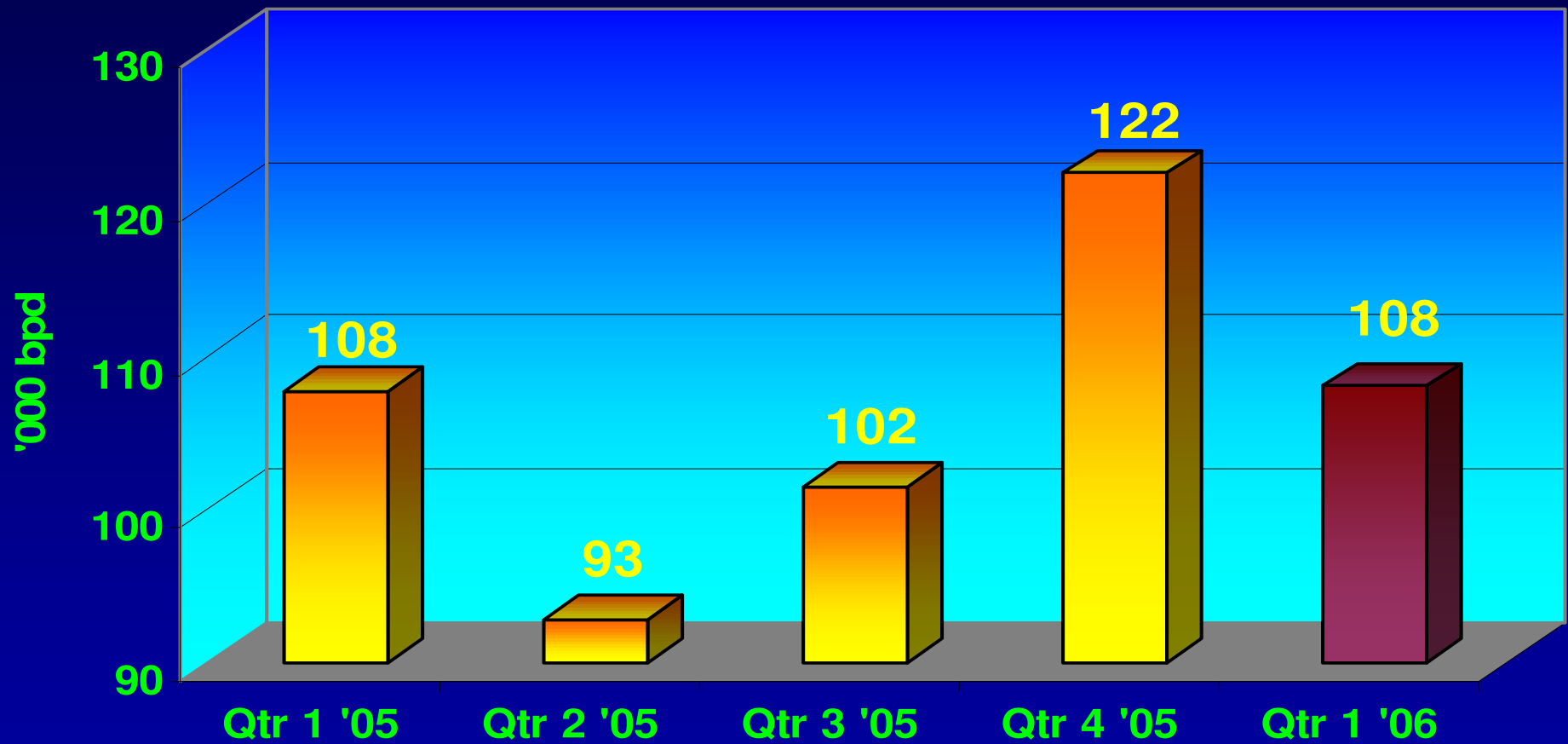

SRC Sales Proceeds

Note:

2001: Drop in crude and product prices

2002: First planned Turnaround of LRCC

2004: Planned Turnaround of Complex 1 in Q1, and Platformer 2 in Q3. Sharp oil price increase.

2005: Planned Turnaround of LRCCU and Complex 2. Oil price kept increasing.

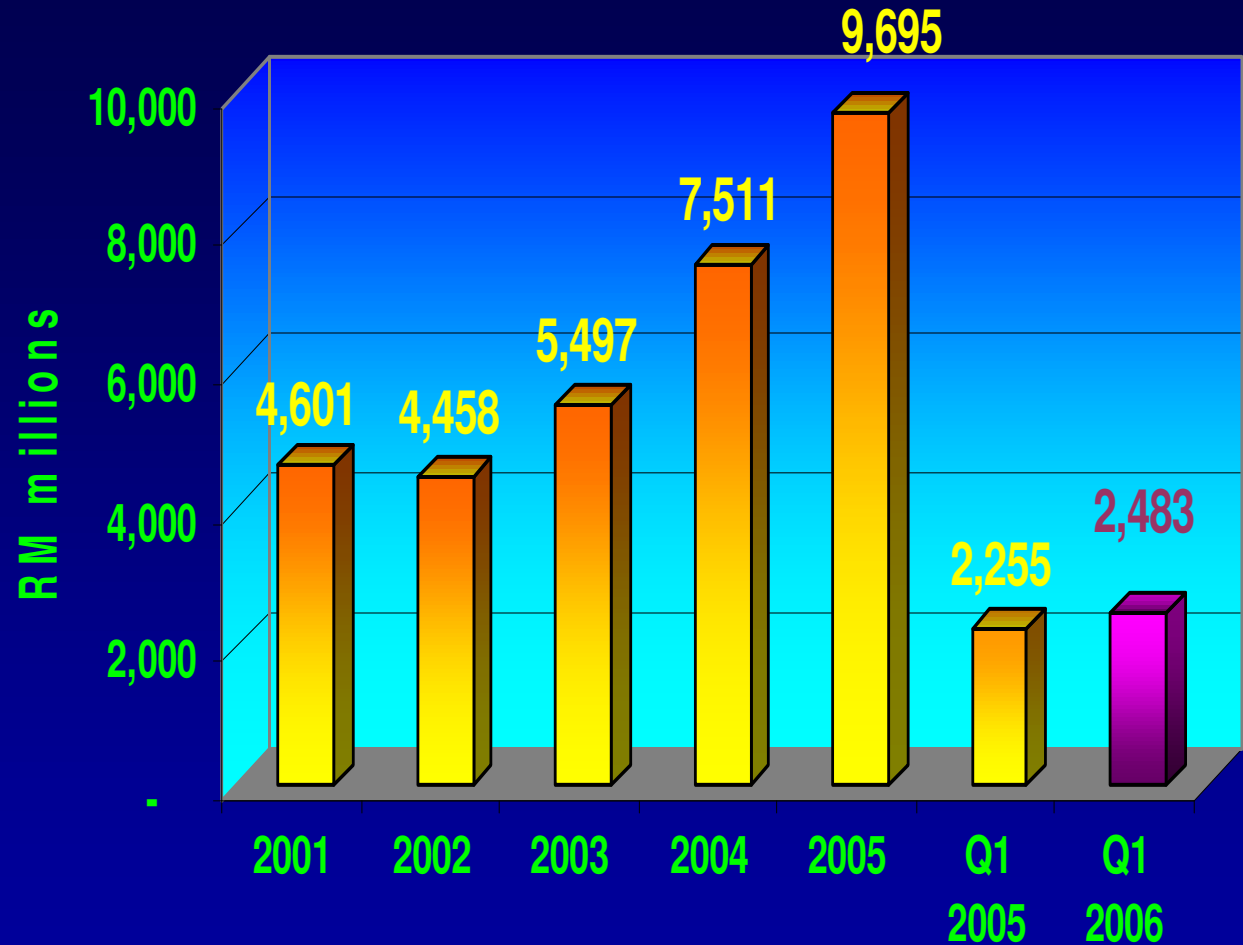

SRC Profit before Taxation

Note:

2001: Drop in crude and product prices resulted in stockholding losses for the Company.

2002-2005: Increase in profits due to strengthening of refining margins, rising crude and product prices* and improvement in operating performance

Q1 2006: Lower realised refining margin and stockholding gain.

* See chart on stockholding gain/loss

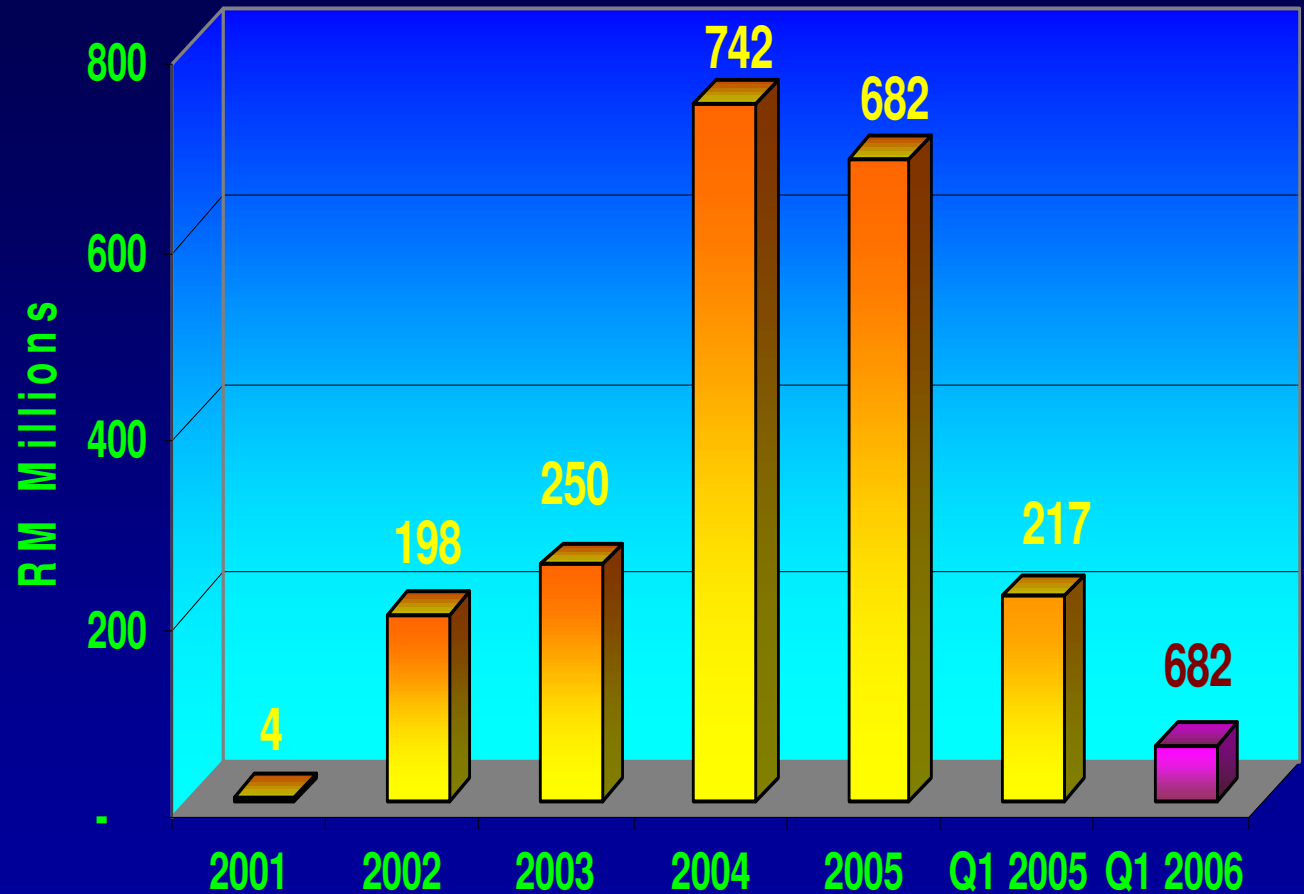

SRC Pre-tax Stockholding Gain/ (Loss)

Note:

In general, we record a stockholding gain in a period of rising (as opposed to high) oil prices, and vice versa.

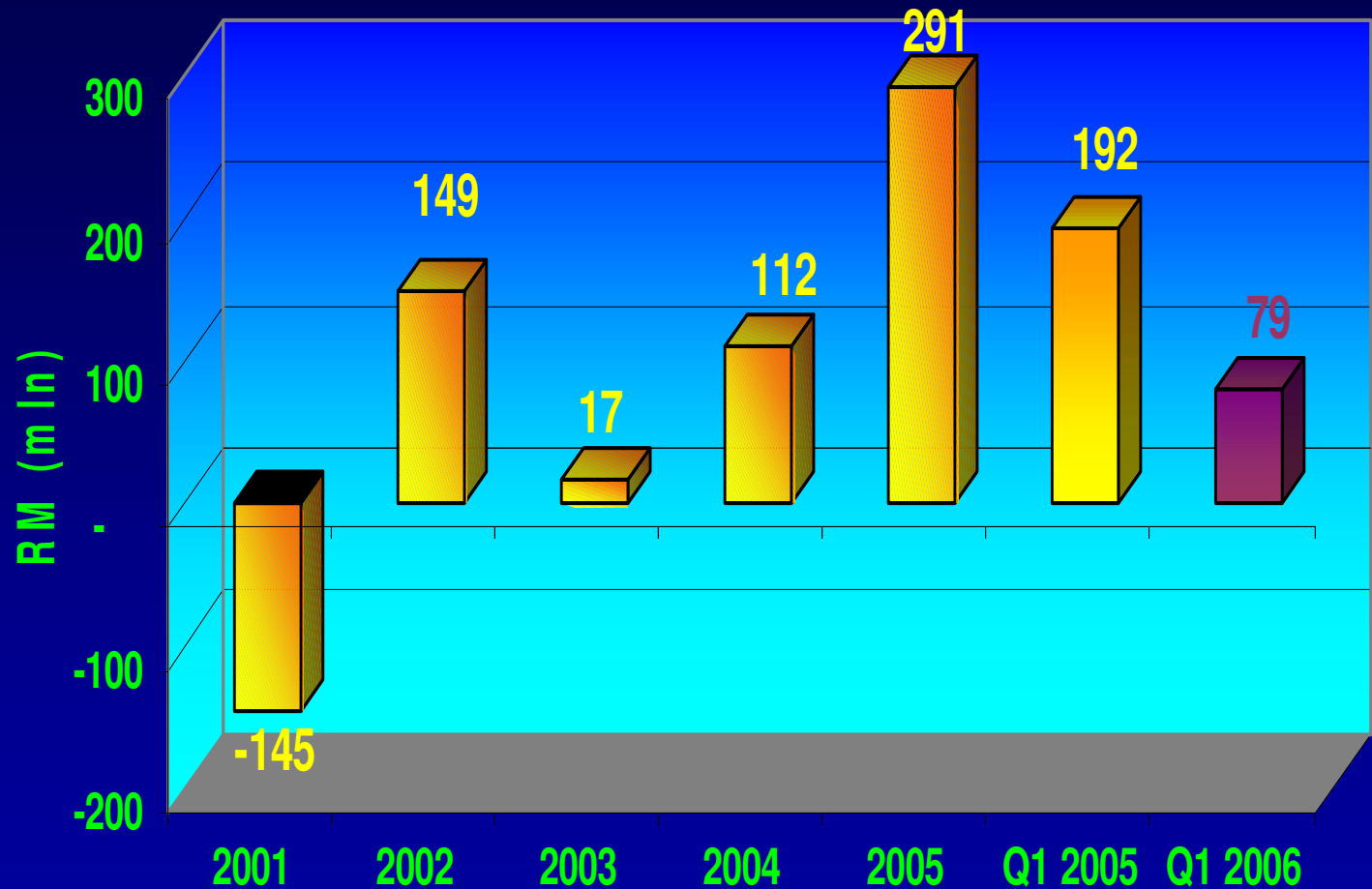

SRC Earnings Per Share

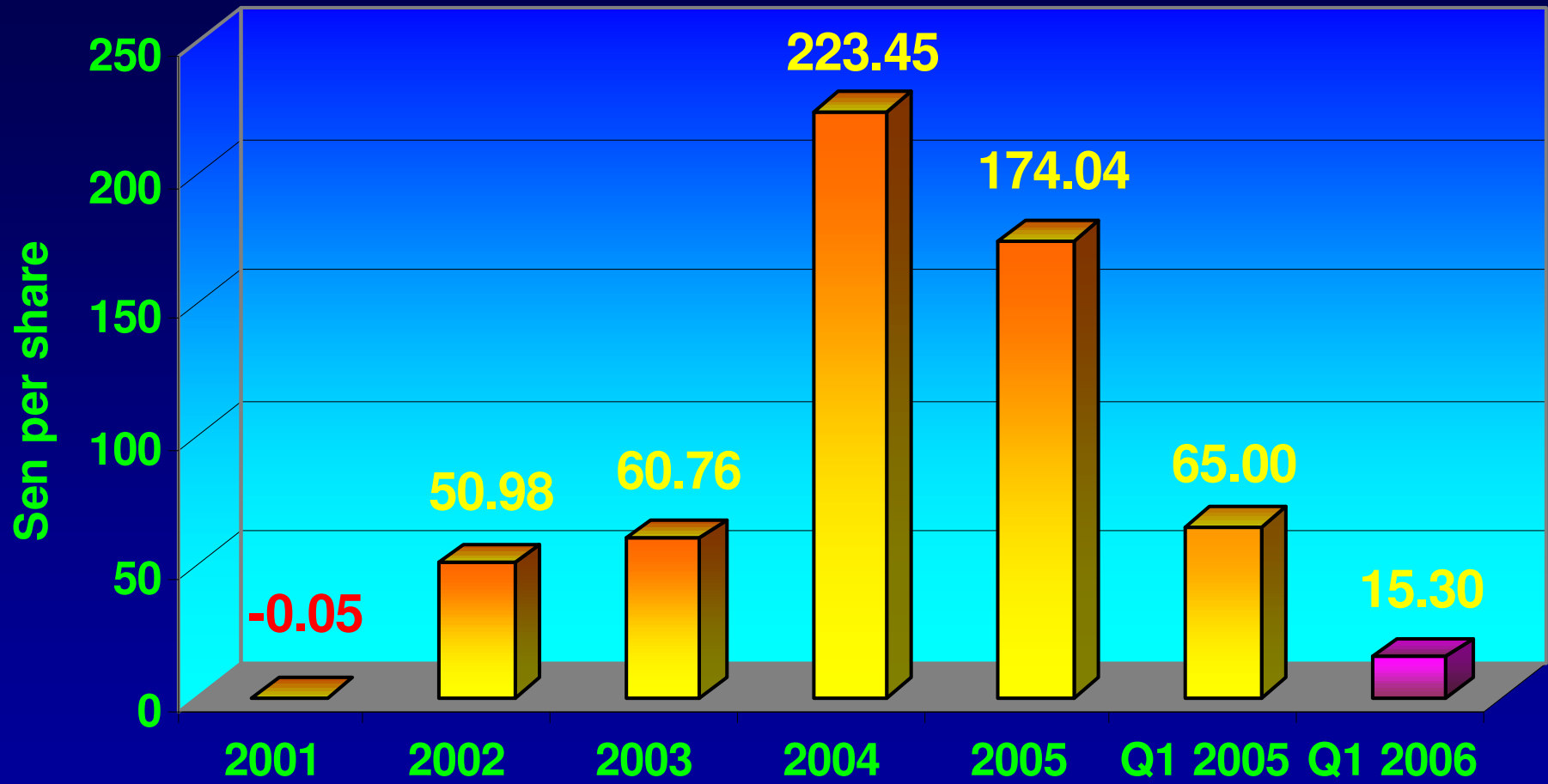

SRC Dividends Per Share

Note:

2005: Includes three special interim dividends totalling 50 sen per share.

2005: Highest ever total dividend per share declared!

Q1 2006: Special interim dividends of 20 sen per share declared.

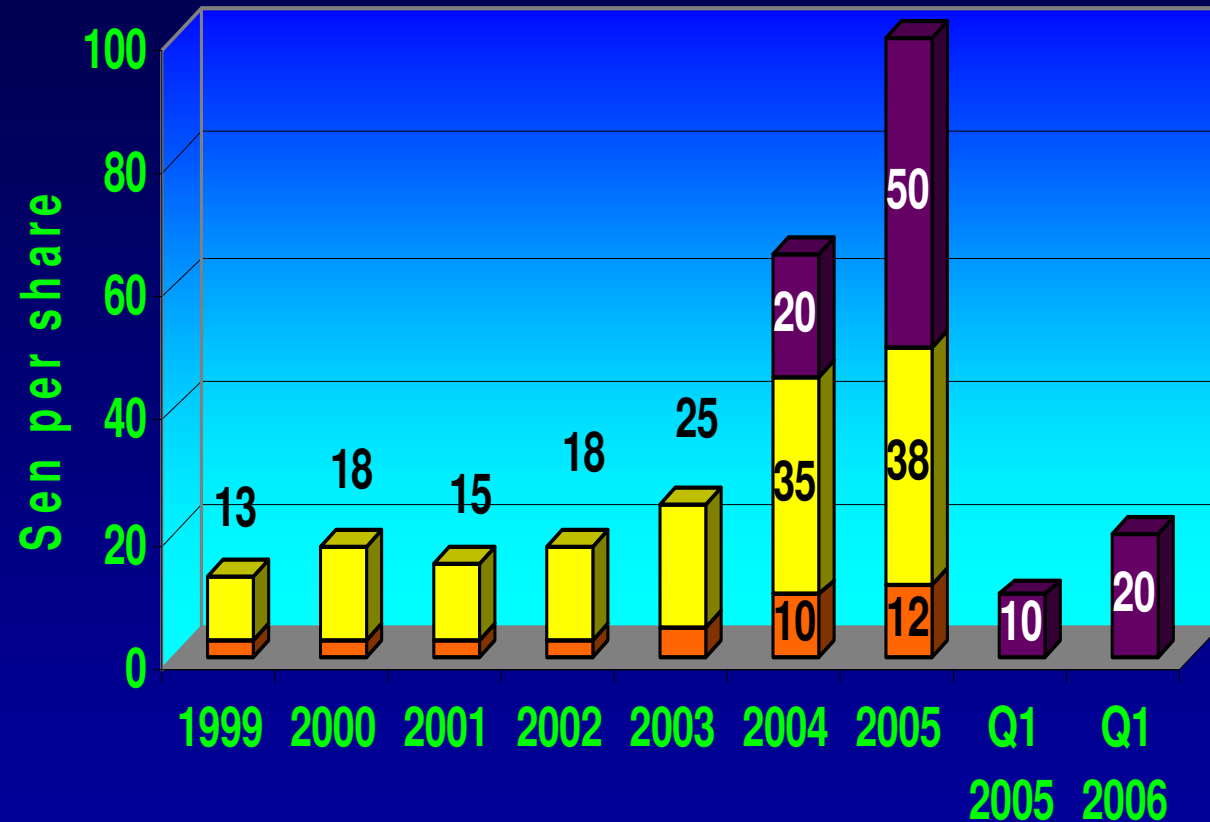

Interim Final Special Interim



SRC Dividend Strategy

"It is the Board's intention that this cash be paid out in the form of a 20 sen per share special interim dividend each quarter until the surplus cash has been utilised. On the basis of current planning assumptions, these special interim dividends would be paid out over the next 4 to 8 quarters...

...The Company also announced today that for the foreseeable future it targets paying a total interim plus final dividend of 50 sen per share, subject to future financial performance."

Press release dated 28th November 2005

"The Company is already delivering on its enhanced dividend strategy as announced on 28th November 2005 and for this year, calendar year 2006, the Company intends to declare a total dividend in the range of RM 0.90 to RM 1.30 per share, consisting of between two and four special dividends of 20 sen paid each quarter, an interim dividend of 12 sen and a final dividend of 38 sen."

Press release dated 23rd February 2006



SRC Financial Summary

Year to Date	Unit	2000	2001	2002	2003	2004	2005	Q1 2005	Q1 2006*
Revenue	RM mil	5184	4,601	4,458	5,497	7,511	9,695	2,255	2,483
EBITDA	RM mil	355	174	336	373	869	819	248	93
Net Income After Tax	RM mil	112	0	153	182	670	522	195	46
Earning per share	Sen	37	-5	51	61	223	174	65	15
Dividends per share	Sen	18	15	18	25	65	100	10	20
P/E Ratio	Times	10	-76	7	7	4	6	14	67
Dividend Yield	%	5	4	5	6	7	10	1	2
Gearing	%	58	53	47	40	27	22	24	21
Net gearing	%	69	57	47	39	19	-5	11	7
Interest Cover	Times	3	1	9	16	65	66	73	30

* Un-audited



SRC Return on Average Capital Employed

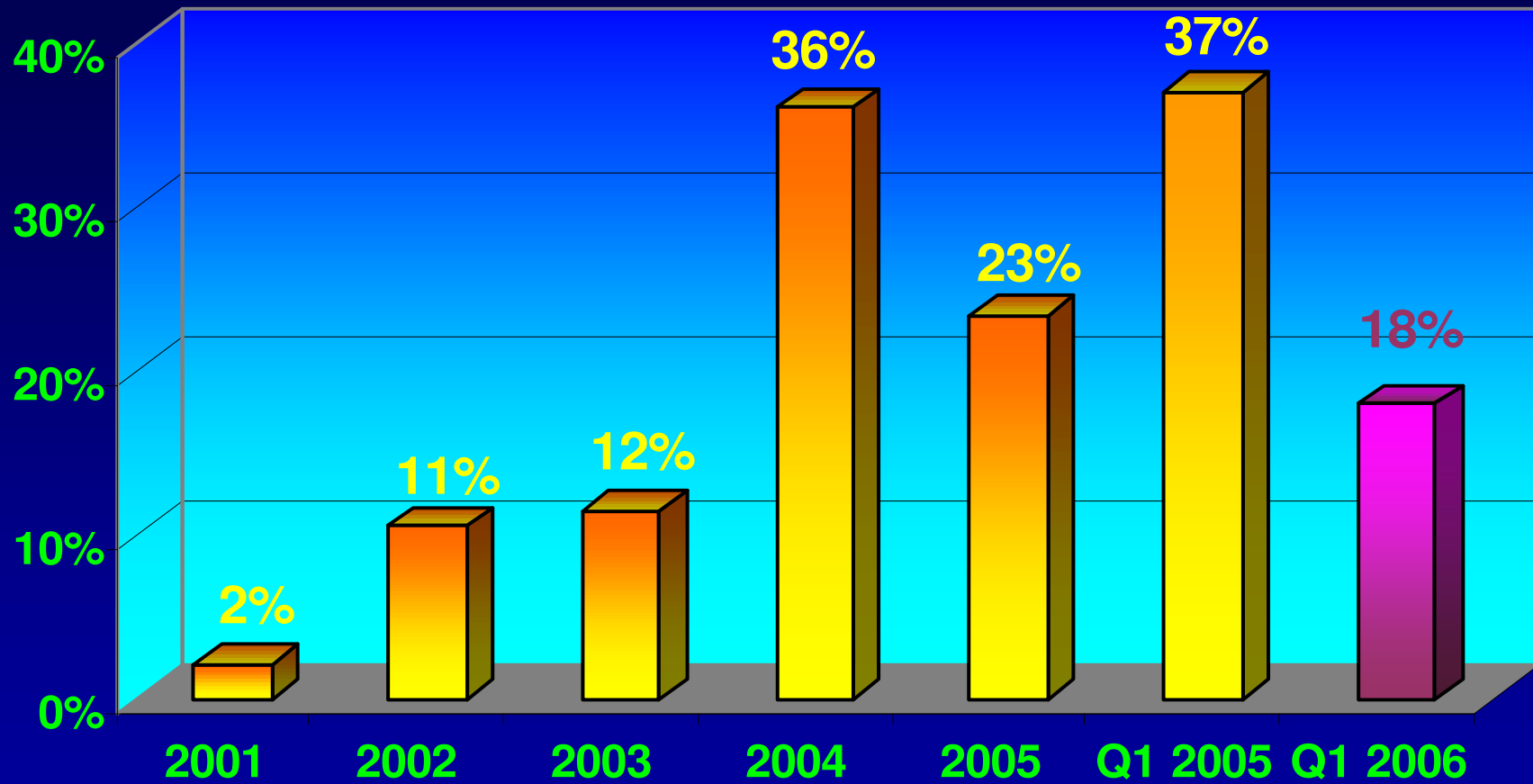

SRC Capital Expenditure

Note:

1999: Final year of LRCC construction

2002: First LRRC planned shutdown

2005: Statutory planned shutdown in June and July

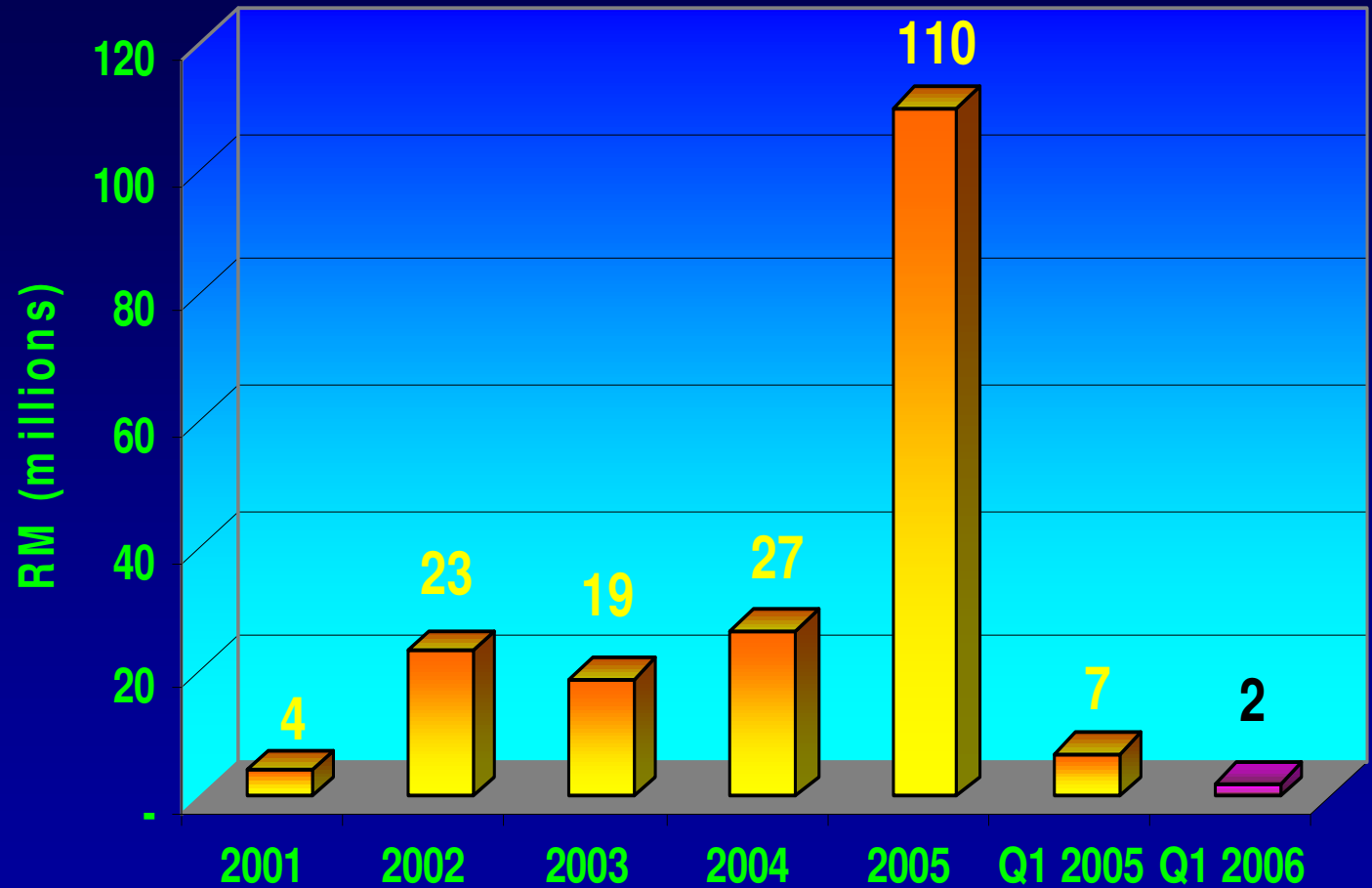

SRC Effective Tax Rate

Note:

2001: Very low Profit Before Tax, therefore a small permanent difference in tax computation has big impact on ETR.

2004: Low ETR due to utilisation of Reinvestment Allowance.

2005: Utilisation of Reinvestment Allowance amounting to RM130 Million.

2006: Temporary differences due to unrealised gain of foreign exchange.

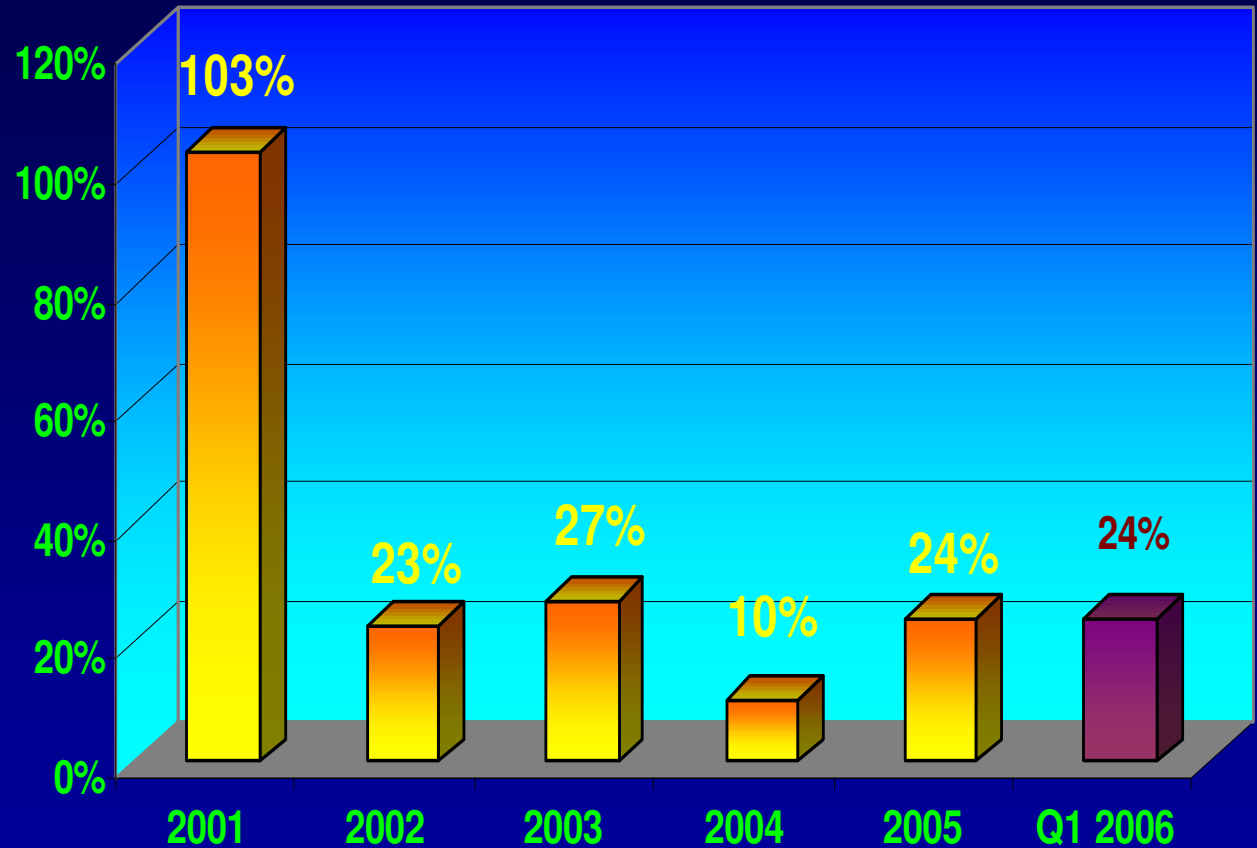

SRC Share Price Performance

SRC Share Price vs Composite Index 2006

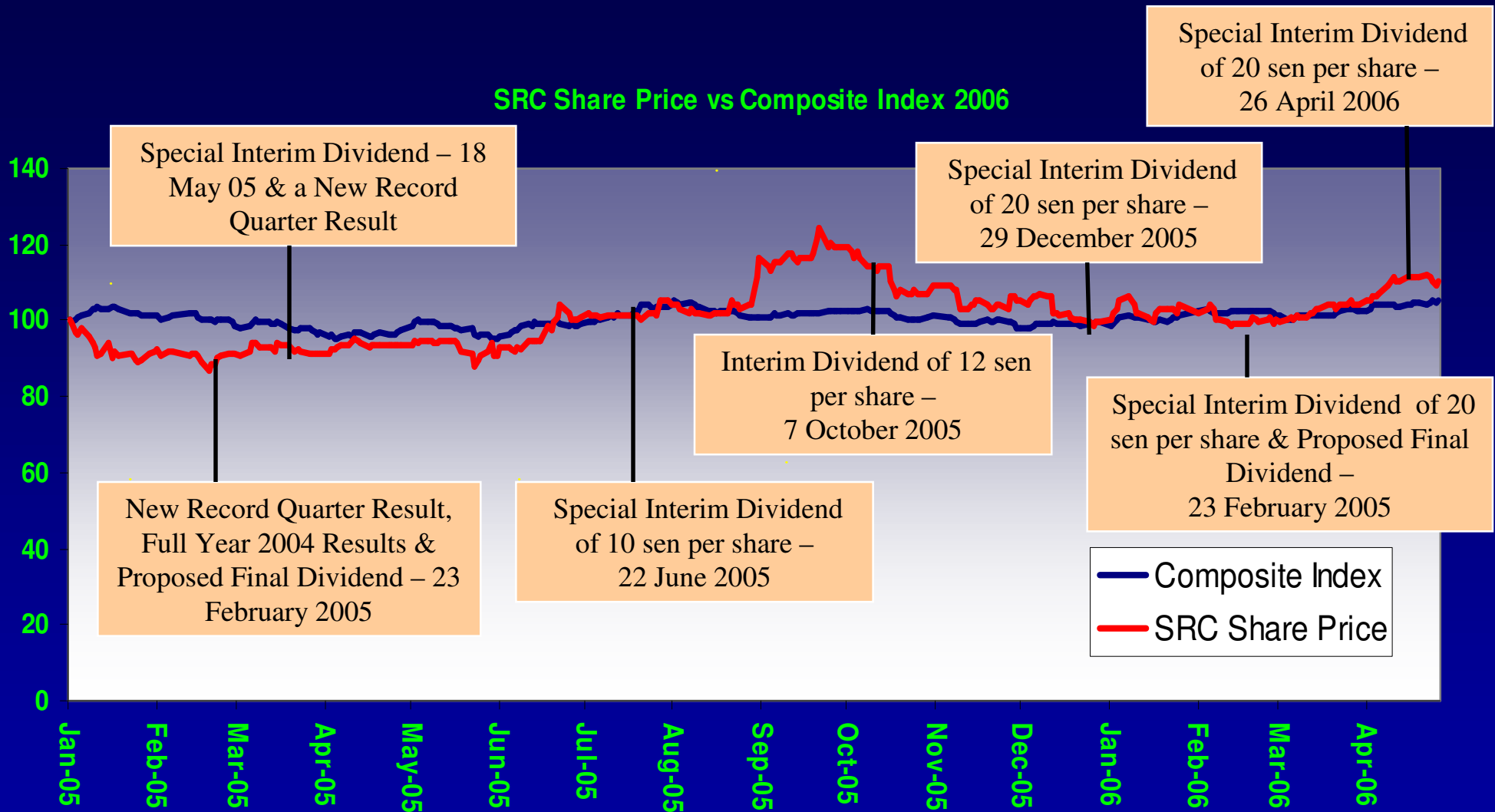

Q & A

Contact details:

Pn. Fardzillah Abdul Manap

Head of Corporate Affairs

Tel: +606-6404119

Fax: +606-6479658

Email: fardzillah.abd-manap@shell.com

